



Bulletin: Electrical Connectors (EK1)

09/08/2015



Mercedes-Benz
Vans. Born to run.

NOTICE:

The specifications, descriptions, information, and recommendations contained in this bulletin are believed to be accurate as of September 8, 2015.

Upfitter Management Vans reserves the right to modify or append this document without prior notification.

This bulletin is not intended as a work instruction, but as a guideline for upfitters to provide technical information necessary to retrofit or modify Mercedes-Benz Sprinters & Freightliner Sprinters (906).

Prior to making any modification to or installing any equipment in or on a Mercedes-Benz Sprinter & Freightliner Sprinter, please consult with Upfitter Management Vans for additional and updated information, and read the Body & Equipment Guidelines for Sprinter Model Series 906.

Upfitter Management Vans Contacts:

For information or upfitter inquiries
please submit a request via our website:

www.upfitterportal.com

Overview

Body Builder electrical connector inside driver seat base X145/1

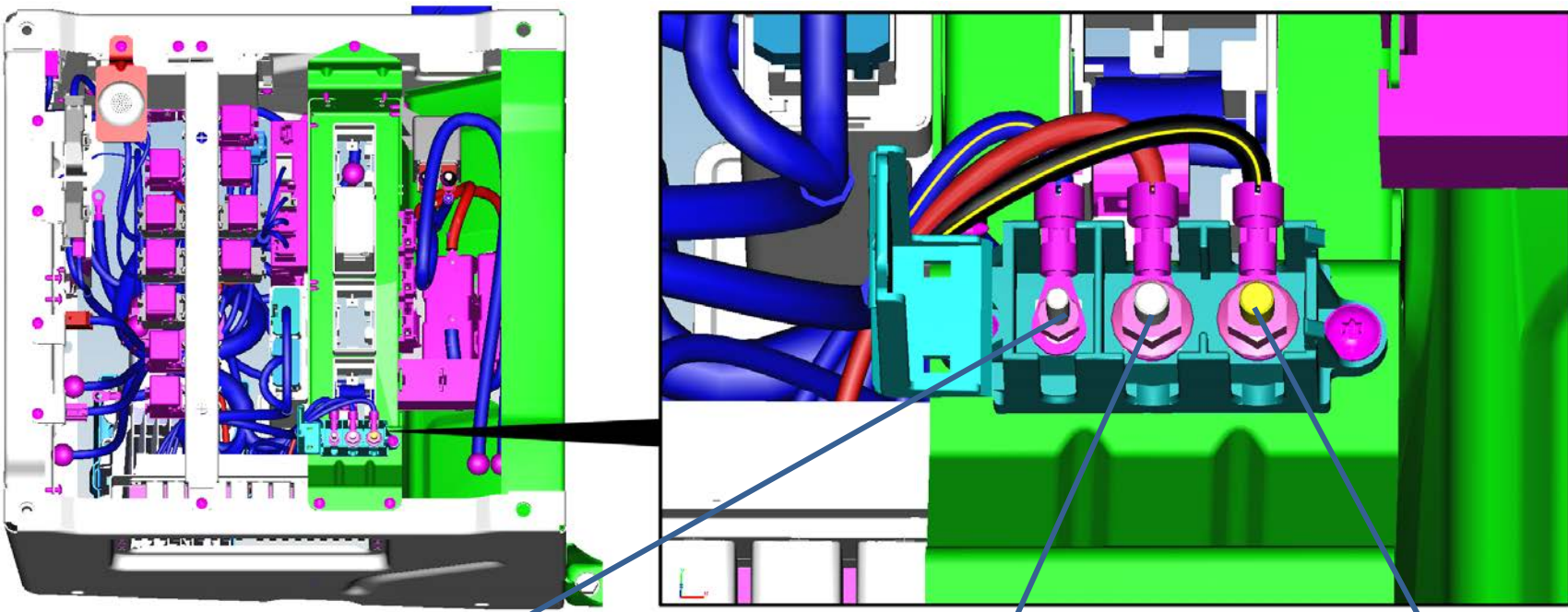

X145/1 Terminal 1 (D+)
 Power with engine running
 Wire color: blue/yellow
 12 V/10 A (120 W)

X145/1 Terminal 2 (30)
 Battery direct power
 Wire color: red/gray
 12 V/25 A (300 W)

X145/1 Terminal 3 (15)
 Ignition power
 Color: black/yellow
 12 V/15 A (180 W)

Overview

Body Builder electrical connector inside driver seat base X145/1

Body Plug Relay K88/1
Power w/engine running
(circuit D+)

Body Plug Relay K88
Ignition power
(circuit 15)

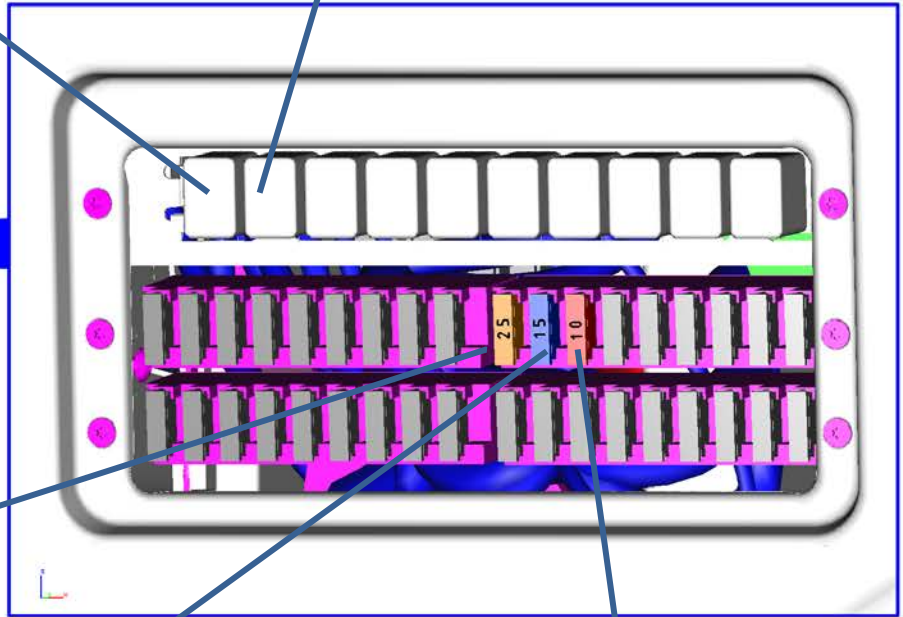
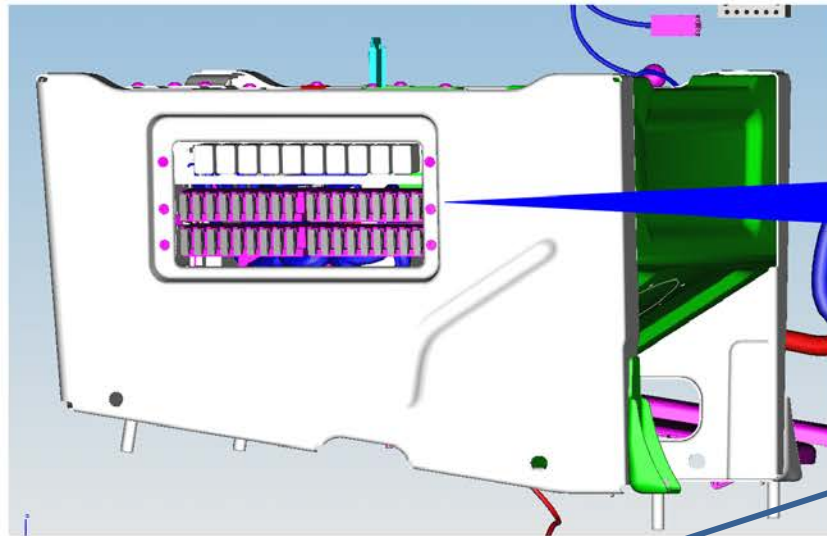

**Body plug fuse 10
(F55/4)**
Battery direct power
25 A

**Body plug fuse 11
(F55/4)**
Ignition power
15 A

Body plug fuse 12 (F55/4)
Power w/engine running
10 A

Overview

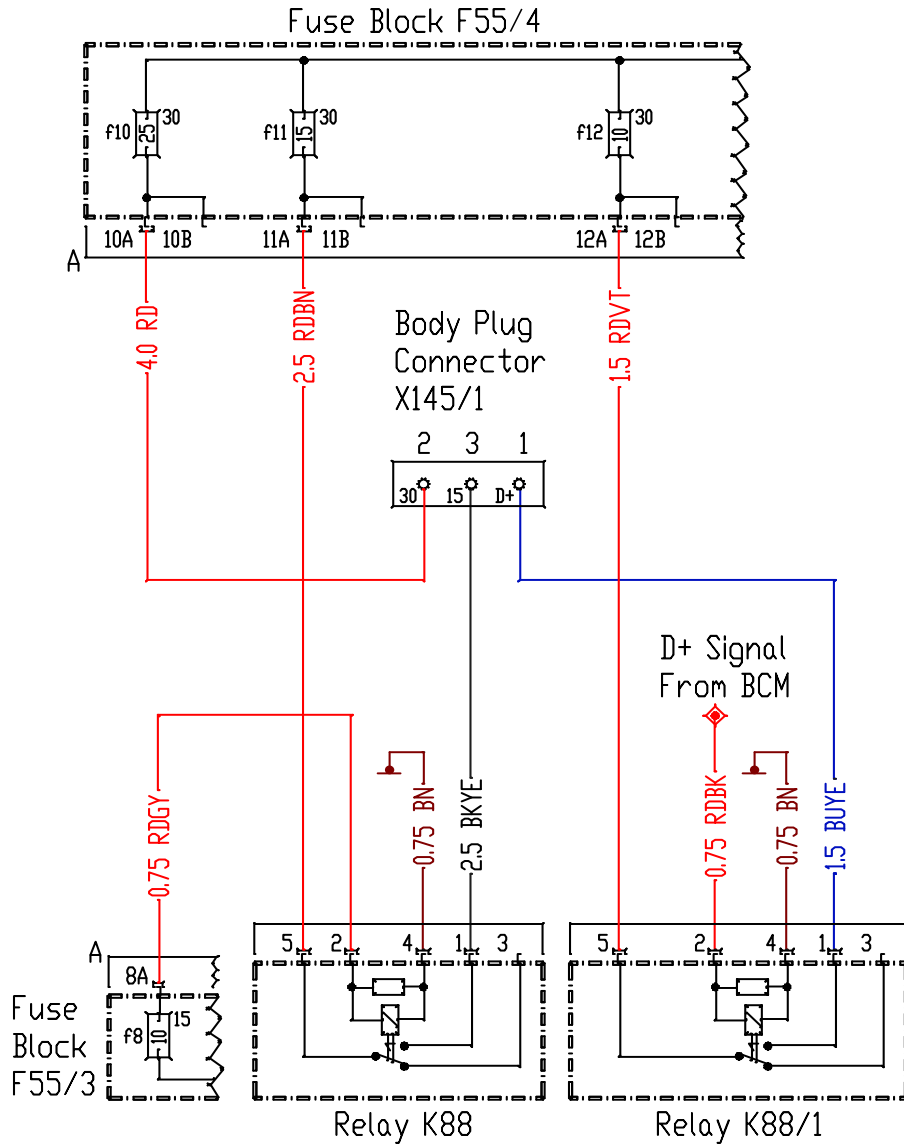

- When installing electrical aftermarket equipment with an AMP draw of more than 25A it is necessary to use the optional aux battery 12V/ 100Ah (CODE E28)
- See Aux Battery retrofitting guidelines